

Atmospheric Pressure GC

Operator's Guide Supplement

715004779 Revision G

Waters

THE SCIENCE OF WHAT'S POSSIBLE.®

Copyright © Waters Corporation 2014
All rights reserved

Copyright notice

© 2014 WATERS CORPORATION. PRINTED IN THE UNITED STATES OF AMERICA AND IN IRELAND. ALL RIGHTS RESERVED. THIS DOCUMENT OR PARTS THEREOF MAY NOT BE REPRODUCED IN ANY FORM WITHOUT THE WRITTEN PERMISSION OF THE PUBLISHER.

The information in this document is subject to change without notice and should not be construed as a commitment by Waters Corporation. Waters Corporation assumes no responsibility for any errors that may appear in this document. This document is believed to be complete and accurate at the time of publication. In no event shall Waters Corporation be liable for incidental or consequential damages in connection with, or arising from, its use. For the most recent revision of this document, consult the Waters Web site (waters.com).

Trademarks

Waters, Xevo, MassLynx, SYNAPT and “THE SCIENCE OF WHAT’S POSSIBLE.” are registered trademarks of Waters Corporation, and NanoLockSpray, is a trademark of Waters Corporation.

Other registered trademarks or trademarks are the sole property of their owners.

Customer comments

Waters' Technical Communications organization invites you to report any errors that you encounter in this document or to suggest ideas for otherwise improving it. Help us better understand what you expect from our documentation so that we can continuously improve its accuracy and usability.

We seriously consider every customer comment we receive. You can reach us at tech_comm@waters.com

Contacting Waters

Contact Waters[®] with enhancement requests or technical questions regarding the use, transportation, removal, or disposal of any Waters product. You can reach us via the Internet, telephone, or conventional mail.

Waters contact information

Contacting medium	Information
Internet	The Waters Web site includes contact information for Waters locations worldwide. Visit www.waters.com .
Telephone and fax	From the USA or Canada, phone 800 252-HPLC, or fax 508 872 1990. For other locations worldwide, phone and fax numbers appear in the Waters Web site.
Conventional mail	Waters Corporation 34 Maple Street Milford, MA 01757 USA

Safety considerations

Some reagents and samples used with Waters instruments and devices can pose chemical, biological, or radiological hazards (or any combination thereof). You must know the potentially hazardous effects of all substances you work with. Always follow Good Laboratory Practice, and consult your organization's standard operating procedures.

Safety hazard symbol notice

Documentation needs to be consulted in all cases where the  symbol is used to find out the nature of the potential hazard and any actions which have to be taken.

Considerations specific to the Atmospheric Pressure GC

High temperature hazard



Warning: To avoid burn injuries, avoid touching the heated transfer line, ion chamber, or heated vial carrier when operating or servicing the instrument.

See also: The relevant Agilent 7890 GC user documentation.

Carrier-gas fire hazard



Warning: To avoid fire, do not use hydrogen (H₂) or other flammable gases as a carrier gas for the APGC.

Hazards associated with removing an instrument from service



Warning: To avoid personal contamination with biologically hazardous, toxic, or corrosive materials, and to avoid spreading contamination to uncontaminated surfaces, wear clean, chemical-resistant, powder-free gloves during all phases of instrument decontamination.



Warning: To avoid puncture injuries, handle syringes, fused silica lines, and borosilicate tips with care.

When you remove the instrument from use to repair or dispose of it, you must decontaminate all of the areas that have been in contact with samples. These are the areas in which you can expect to encounter the highest levels of contamination:

- Source interior
- APGC ion chamber
- GC components

Do not dispose of the instrument or return it to Waters for repair until the authority responsible for approving its removal from the premises specifies the extent of decontamination required, and the level of residual contamination permissible. That authority must also prescribe the method of decontamination to be used, and the appropriate protection for personnel undertaking the decontamination process.

You must handle items such as syringes, fused silica lines, and borosilicate tips used to carry sample into the source area in accordance with laboratory procedures for contaminated vessels and sharps.

See also: The relevant Agilent 7890 GC user documentation.

Electrical power safety notice

Do not position the instrument so that it is difficult to operate the disconnecting device.









Safety advisories



Consult [Appendix A](#) for a comprehensive list of warning and caution advisories.

Operating this device

When operating this device, follow standard quality-control (QC) procedures and the guidelines presented in this section.

Applicable symbols

Symbol	Definition
	Manufacturer
	Date of manufacture
	Part number catalog number
	Serial number
	Supply ratings
	Authorized representative of the European Community
	Confirms that a manufactured product complies with all applicable European Community directives
	Australia EMC Compliant
	Confirms that a manufactured product complies with all applicable United States and Canadian safety requirements

Symbol	Definition
	Consult instructions for use
	<p>Electrical and electronic equipment with this symbol may contain hazardous substances and should not be disposed of as general waste.</p> <p>For compliance with the Waste Electrical and Electronic Equipment Directive (WEEE) 2012/19/EU, contact Waters Corporation for the correct disposal and recycling instructions.</p>

Audience and purpose

This guide presents user installation, setup, and safety information for the Waters Atmospheric Pressure Gas Chromatograph (APGC) used with compatible mass spectrometers.

Intended use of the APGC

The APGC allows coupling of a GC (gas chromatography) instrument to the atmospheric pressure ionization (API) source on compatible LCMS instruments. The APGC is for research use only. It is not intended for use in diagnostic applications. It is intended for use only by qualified laboratory personnel, installation engineers, and field service engineers.

Calibrating

To calibrate GC systems, follow acceptable calibration methods using at least five standards to generate a standard curve. The concentration range for standards should include the entire range of QC samples, typical specimens, and atypical specimens.

When calibrating mass spectrometers, consult the calibration section of the operator's guide for the instrument you are calibrating. In cases where an overview and maintenance guide, not operator's guide, accompanies the instrument, consult the instrument's online Help system for calibration instructions.

Quality control

Routinely run three QC samples that represent subnormal, normal, and above-normal levels of a compound. Ensure that QC sample results fall within an acceptable range, and evaluate precision from day to day and run to run. Data collected when QC samples are out of range might not be valid. Do not report these data until you are certain that the instrument performs satisfactorily.

ISM classification

ISM Classification: ISM Group 1 Class A

This classification has been assigned in accordance with IEC CISPR 11 Industrial Scientific and Medical (ISM) instruments requirements. Group 1 products apply to intentionally generated and/or used conductively coupled radio-frequency energy that is necessary for the internal functioning of the equipment. Class A products are suitable for use in commercial (that is, nonresidential) locations and can be directly connected to a low voltage, power-supply network.

FCC radiation emissions notice

Changes or modifications not expressly approved by the party responsible for compliance, could void the users authority to operate the equipment. This device complies with Part 15 of the FCC Rules. Operation is subject to the following two conditions: (1) this device may not cause harmful interference, and (2) this device must accept any interference received, including interference that may cause undesired operation.

EC authorized representative



Waters Corporation
Stamford Avenue
Altrincham Road
Wilmslow
SK9 4AX
United Kingdom

Telephone: +44-161-946-2400
Fax: +44-161-946-2480
Contact: Quality manager

Table of Contents

Copyright notice	ii
Trademarks	ii
Customer comments	iii
Contacting Waters	iii
Safety considerations	iv
Safety hazard symbol notice.....	iv
Considerations specific to the Atmospheric Pressure GC	iv
Electrical power safety notice	v
Safety advisories	v
Operating this device	vi
Applicable symbols	vii
Audience and purpose.....	viii
Intended use of the APGC	viii
Calibrating	viii
Quality control	ix
ISM classification	ix
ISM Classification: ISM Group 1 Class A	ix
FCC radiation emissions notice	ix
EC authorized representative	x
1 Instrument Description	15
Waters APGC	16
APGC components	18
APGC trolley (SYNAPT G2 only).....	19
Heated transfer line.....	22
APGC source enclosure.....	23
Heated and unheated vial carriers	24
APGC ion chamber	25

2	Setting up the APGC	27
	Preparing the mass spectrometer for operation with the APGC	28
	Preparing the instrument for work performed on its source.....	28
	Removing the LC source enclosure from the mass spectrometer.....	29
	Preparing the source ion block for GC operation	31
	Installing the APGC ion chamber on the mass spectrometer's ion block.....	35
	Installing the APGC source enclosure in the mass spectrometer	38
	Installing the APGC vial carriers in the mass spectrometer's source	39
	Installing vials in the vial carriers	40
	Connecting the APGC to the mass spectrometer	42
	Disconnecting the APGC from the mass spectrometer	43
	Removing vials from the vial carriers	44
	Preparing the mass spectrometer for LC operation	45
	Removing the APGC vial carriers from the mass spectrometer's source	45
	Removing the APGC source enclosure from the mass spectrometer	46
	Removing the APGC ion chamber from the mass spectrometer's ion block...	47
	Preparing the source ion block for LC operation	48
	Installing the LC source enclosure on the instrument	50
3	Maintenance Procedures	51
	Maintenance schedule	52
	Spare parts	52
	Safety and handling	53
	Cleaning the mass spectrometer sample cone	54
	Cleaning or replacing the corona pin	54
	Cleaning the APGC ion chamber	57
A	Safety Advisories	59
	Warning symbols	60
	Task-specific hazard warnings.....	60

Specific warnings	61
Notices	64
Prohibition symbol	64
Warnings that apply to all Waters instruments and devices	65
Warnings that address the replacing of fuses	70
Electrical and handling symbols	72
Electrical symbols	72
Handling symbols	73
B Installing the GC Column	75
C Preparing Sample Vials	79
Preparing vials	80
Preparing closed vials.....	80
Preparing open vials.....	81

1

Instrument Description

The Waters® Atmospheric Pressure GC (APGC) couples an Agilent GC with a compatible Waters LCMS instrument. Doing so makes possible performing LC and GC analyses in the same system, without compromising performance. It also avoids the need for separate, dedicated GCMS and LCMS instrumentation.

Contents:

Topic	Page
Waters APGC	16
APGC components	18

Waters APGC

The APGC provides complementary information to the LCMS instrument, enabling analysis of compounds of low molecular weight or low-to-intermediate polarity.

The APGC is compatible with these Waters LCMS instruments:

- Xevo[®] TQ MS
- Xevo TQ-S micro
- Xevo TQ-S
- Xevo TQD
- Xevo QToF MS
- Xevo G2 QToF
- Xevo G2 ToF
- SYNAPT[™] G2 MS
- SYNAPT G2 HDMS
- SQ Detector 2

See also: The relevant instrument's operator's overview and maintenance guide. For correct operation and maintenance of the GC oven and capillary column, refer to the relevant manufacturer's user documentation.

Agilent GC and autosampler mounted on the APGC platform:

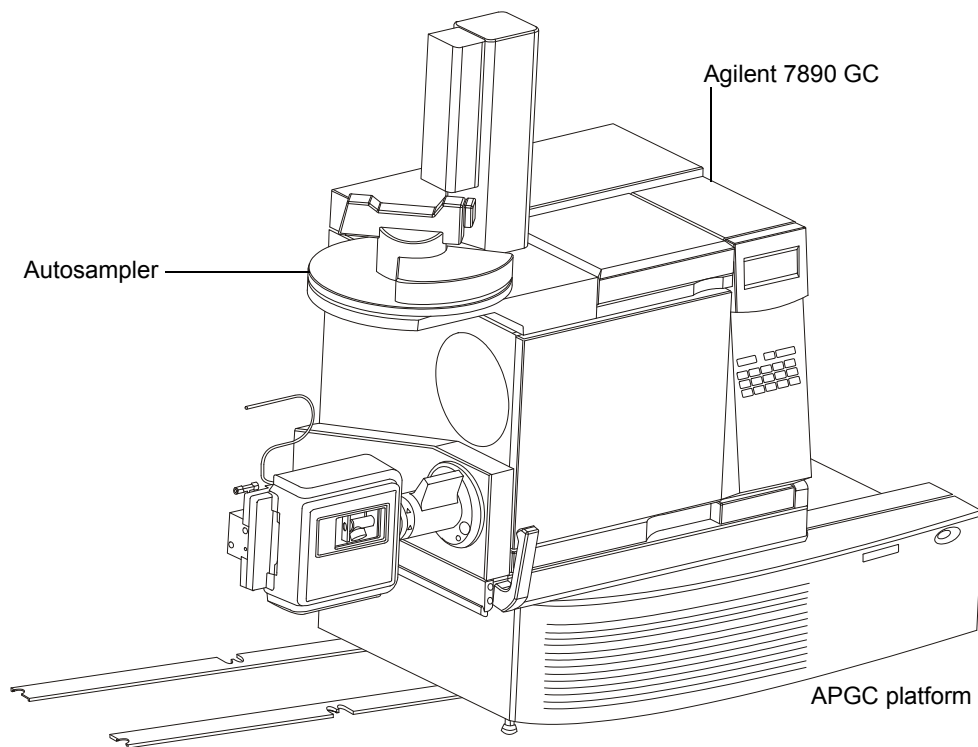

APGC components

The APGC comprises a sliding platform mounted on a supporting plinth, which can hold an accessory storage drawer, depending on the mass-spectrometer model. The platform carries the heated transfer line and the GC instrument, which the mass spectrometer connects to via the APGC source enclosure and ion chamber. A locking handle locks the sliding platform, preventing its unintentional movement when you disconnect the locking ring from the APGC source enclosure. The stability frame, which a Waters engineer installs, mechanically locks the APGC to the mass spectrometer.



Warning: To avoid injury from being struck by toppling equipment,

- do not overbalance the equipment by placing in the accessory-storage drawer (where fitted) a load exceeding 10 kg;
- do not tamper with the stability frame.

APGC main components:

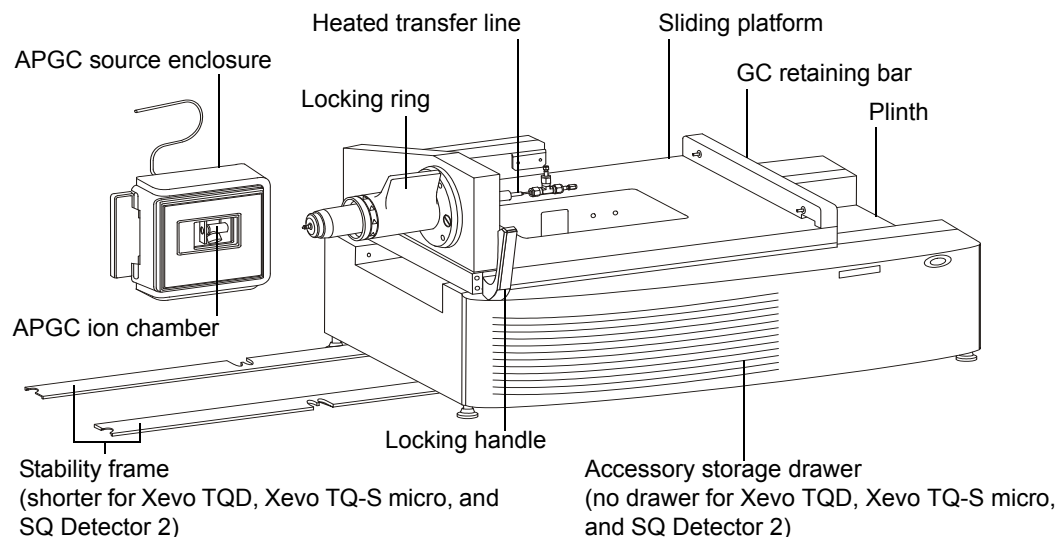

When you operate the mass spectrometer in GCMS mode, the APGC source enclosure and APGC ion chamber serve in place of the standard mass-spectrometer source enclosure and cone gas nozzle.

You can quickly interchange the mass spectrometer and APGC source enclosures, to adapt the mass spectrometer to LCMS or GCMS configuration.

APGC trolley (SYNAPT G2 only)

The optional APGC trolley allows you to use the APGC with SYNAPT G2 instruments. Note that the stability frame is not required with this version of the APGC.

APGC trolley:

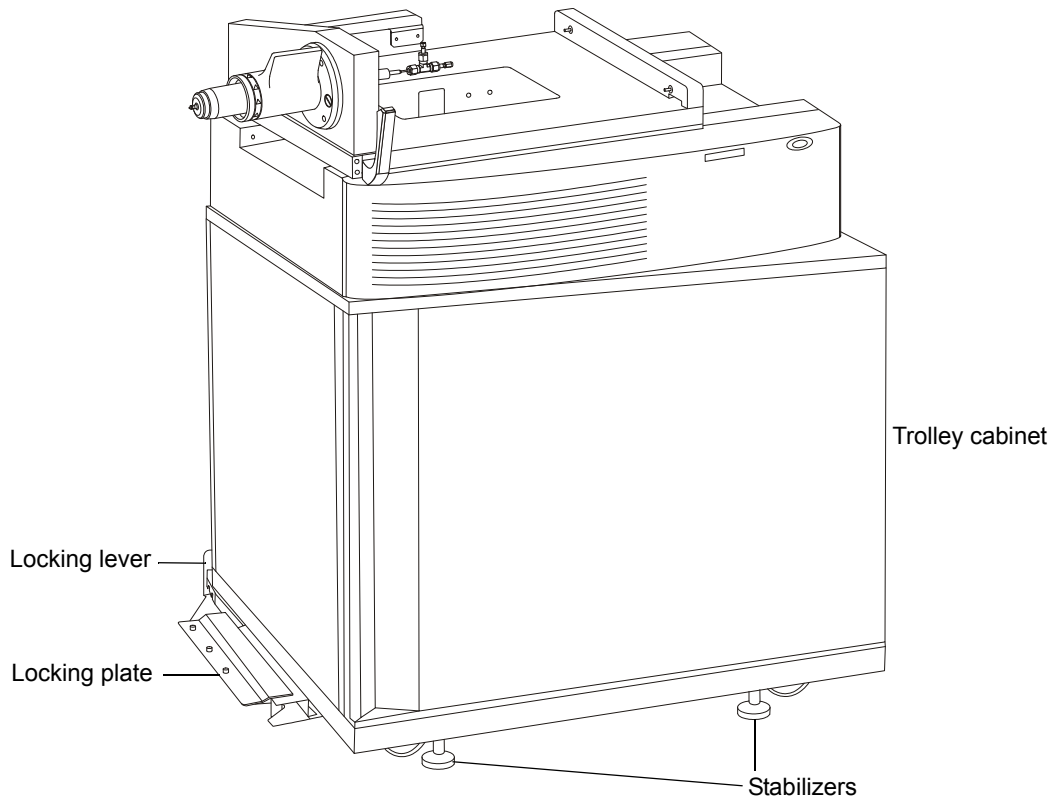

The APGC trolley is a mobile steel cabinet on top of which the APGC is fixed in place. A locking lever and locking plate engage or disengage the trolley and mass spectrometer.

Engaging the APGC trolley:

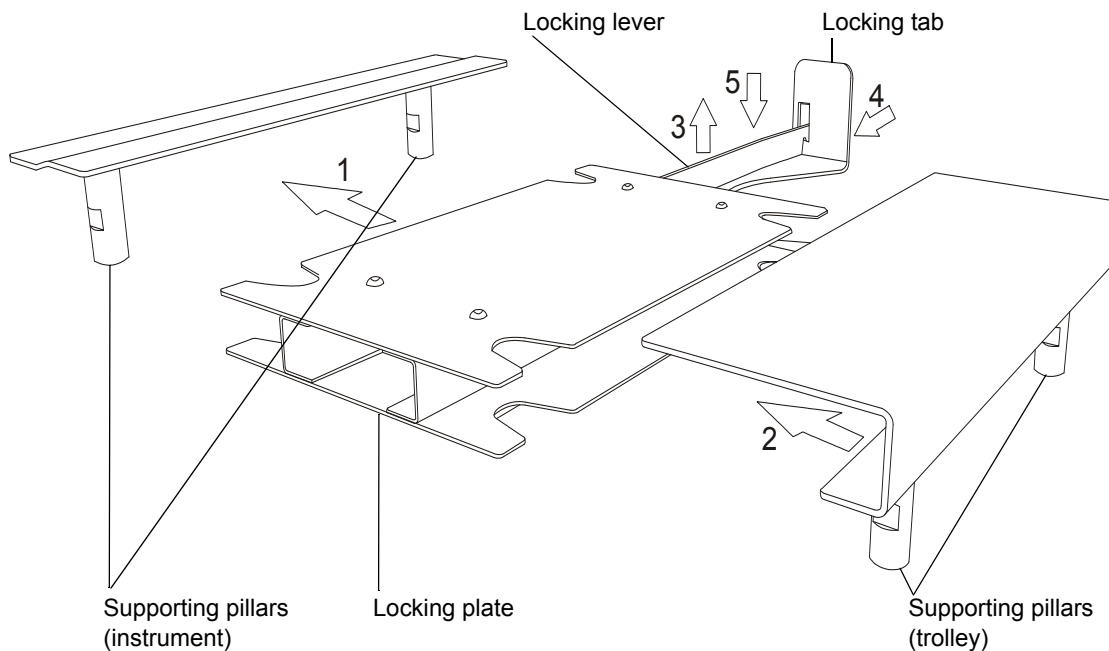

To engage the APGC trolley:

1. Slide the locking plate forward so that the two indentations meet the supporting pillars under the instrument.
2. Push the trolley toward the locking plate so that the two indentations meet the supporting pillars under the trolley.
3. Lift the locking lever.
4. Push the locking tab toward the locking plate as far as it will go.
5. Release the locking lever, ensuring that the inner notch engages firmly with the locking tab.
6. Adjust the stabilizers until the trolley is entirely stable, level, and at a suitable height for the heated transfer line to engage with the instrument source.

Tip: Use a spirit level to ensure that the trolley is level.

Disengaging the APGC trolley:

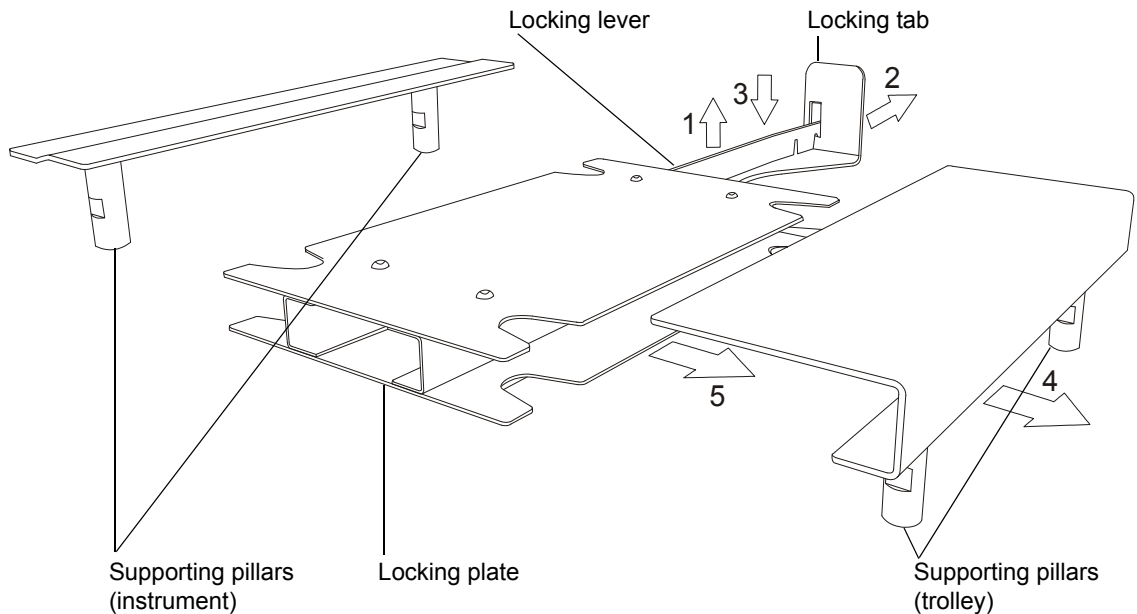

To disengage the APGC trolley:

Requirement: Before performing this procedure, ensure that you have first loosened the stabilizers under the trolley.

1. Lift the locking lever.
2. Pull the locking tab outward as far as it will go.
3. Drop the locking lever so that the outermost notch engages with the locking tab.
4. Carefully slide the trolley away from the locking plate.
5. Pull the locking plate away from the instrument.

Heated transfer line

To ensure the equipment's proper operation, a Waters service engineer establishes the optimum position of the heated transfer line within the mass spectrometer's source.

Important: Once the position of the heated transfer line is set, you must not change it.

 **Warning:** To avoid burn injuries, take great care when working with the heated transfer line. The line heats during normal use, and hot gas can escape from the capillary column's tip. Use the APGC protection cap to cover the tip when you withdraw the tube from the source enclosure for extended periods.

 **Warning:** To avoid burn injuries, the locking ring of the heated transfer line must be replaced by a Waters field engineer when the line is defective.

 **Notice:** To avoid damaging the capillary column, do not operate the heated transfer line at temperatures greater than those recommended by the capillary column manufacturer.

Heated transfer line assembly:

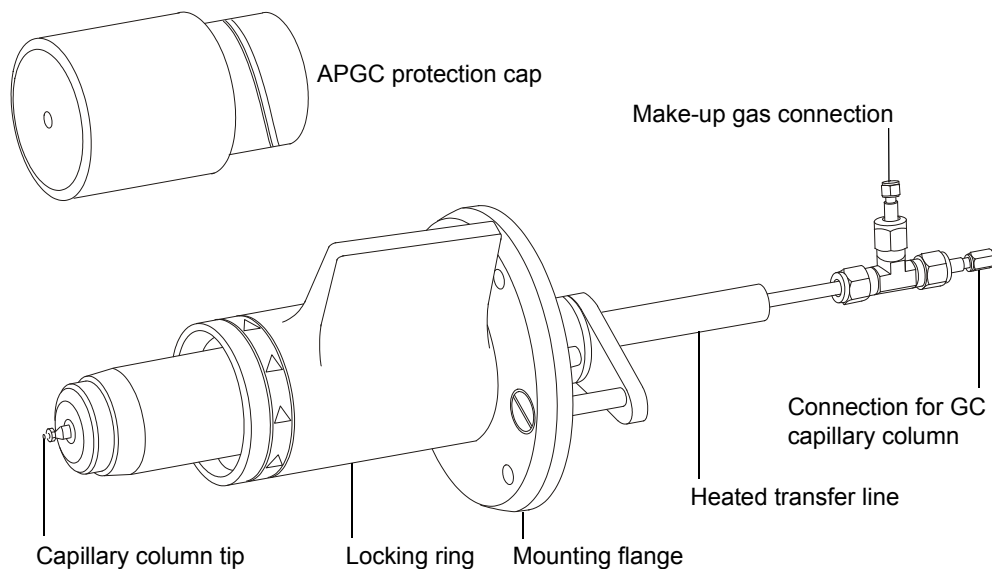

The heated transfer line positions the capillary column tip in the correct location relative to the APGC ion chamber within the mass spectrometer's source enclosure.

Turning the locking ring through 180° locks the transfer line to the APGC source housing.

APGC source enclosure

You can easily remove the APGC source enclosure and ion chamber from the mass spectrometer, so that you can install a standard source enclosure, when required.

APGC source enclosure front/rear views:

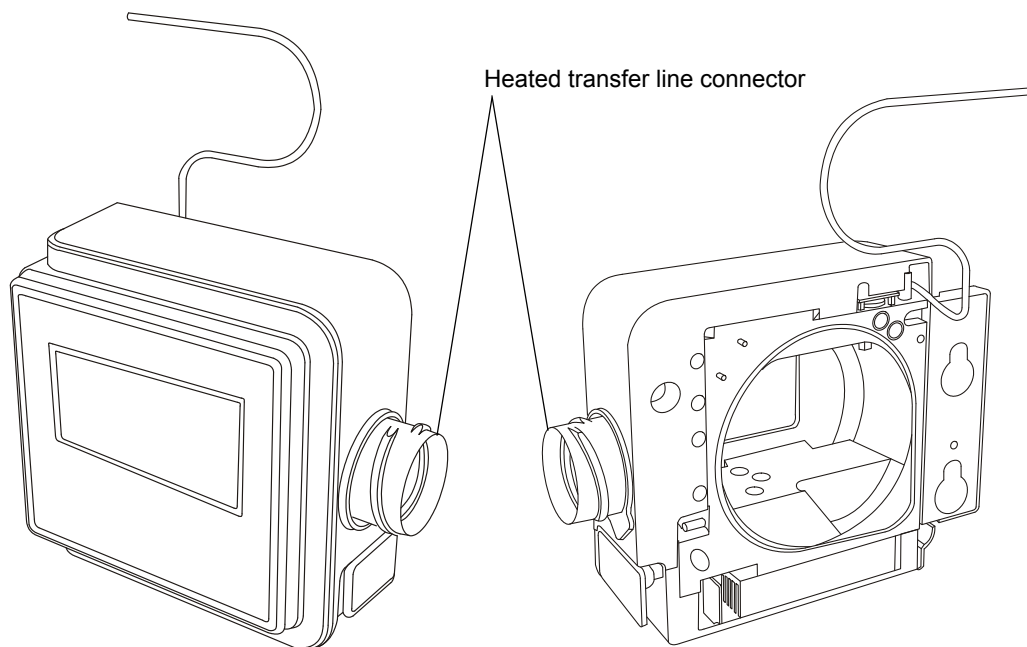

Heated and unheated vial carriers



Warning: To avoid burn injuries, take great care when working with the heated vial carrier and vials. The mass spectrometer's source ion block becomes hot during normal use.

The APGC source enclosure incorporates two removable vial carriers (heated and unheated). Each carrier can contain up to three vials:

- The heated vial carrier is located on top of the mass spectrometer's source ion block.
- The unheated vial carrier is located in the bottom of the source enclosure.

Source internal components:

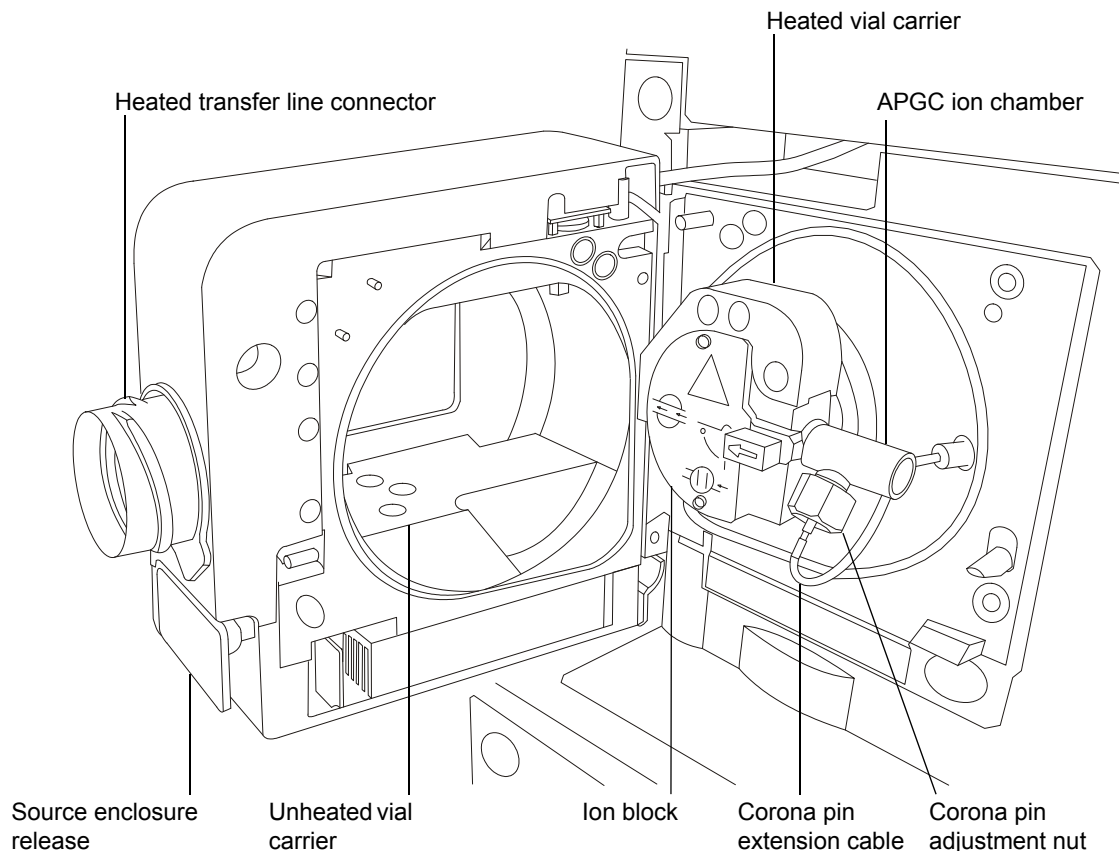

APGC ion chamber

For APGC operation, the APGC ion chamber mounts on the ion block, in place of the cone gas nozzle. The APGC ion chamber positions the corona pin relative to the mass spectrometer's sample cone. Although the layout differs, the corona pin is functionally identical to the corona pin used in LC operation.

Requirements:

- During APGC operation with the Xevo TQD or SQ Detector 2 mass spectrometer, you must use the reduced-aperture, 0.36-mm, sample cone supplied with the APGC, to avoid problems associated with unstable signal intensity.
- During LC operation with the Xevo TQD or SQ Detector 2 mass spectrometer, you must use the original, 0.50-mm, sample cone supplied with the instrument, to avoid problems associated with low sensitivity.

See also: The relevant instrument's operator's overview and maintenance guide.

1 Instrument Description

2 Setting up the APGC

You must set up the APGC and otherwise prepare it for operation with compatible instruments. Refer to the online Help for information about operating the APGC.

Contents:

Topic	Page
Preparing the mass spectrometer for operation with the APGC...	28
Installing vials in the vial carriers.....	40
Connecting the APGC to the mass spectrometer	42
Disconnecting the APGC from the mass spectrometer	43
Removing vials from the vial carriers.....	44
Preparing the mass spectrometer for LC operation.....	45



Preparing the mass spectrometer for operation with the APGC

For additional information, see the mass spectrometer's operator's overview and maintenance guide.

Preparing the instrument for work performed on its source

Follow the relevant procedure for your instrument before working on the source: for example, when installing or removing the corona pin or ion chamber, operating the source isolation valve, or maintaining the source.

To prepare the Xevo TQ MS, Xevo TQ-S micro, Xevo TQ-S, Xevo TQD, or SQ Detector 2:

1. In the MassLynx™ Tune window, click Standby .
2. Set the source temperature to 30 °C.
3. Wait 30 minutes, to allow the source to cool.
4. In the Tune window, click API , to stop the API gas flow.

To prepare the Xevo QTof MS, Xevo G2 QTof, Xevo G2 Tof, or SYNAPT G2 MS/HDMS:

1. In the Tune window, click Source Standby .
2. Set the source temperature to 30 °C.
3. Wait 30 minutes, to allow the source to cool.

Note: The API gas flow stops automatically when you click Source Standby.

See also: The relevant instrument's operator's overview and maintenance guide.

Removing the LC source enclosure from the mass spectrometer

You must remove the currently fitted source enclosure from the mass spectrometer before installing the APGC source enclosure.

Required materials

- Chemical-resistant, powder-free gloves
- Needle-nose pliers



Warning: To avoid personal contamination with biologically hazardous, toxic, or corrosive materials, and to avoid spreading contamination to uncontaminated surfaces, wear clean, chemical-resistant, powder-free gloves when working with the probe and the source components.



Warning: To avoid electric shock, prepare the instrument for work performed on its source (see [page 28](#)) before removing the source enclosure.

To remove the source enclosure:

1. Prepare the instrument for working on its source (see [page 28](#)).



Warning: To avoid burn injuries, take great care while working with the source components, which can be hot.



Warning: To avoid puncture wounds, take great care when removing an ESI probe; the probe tip is sharp.

2. Slide the instrument's source interface door open.
3. Disconnect the probe adjuster and options cables from the instrument's connectors.
4. Slide the instrument's source interface door closed.



Warning: To avoid puncture wounds, take great care when the corona pin is in place and you are working with the source enclosure open. The tip of the corona pin is sharp.



Notice: To avoid damaging the sample inlet, when removing a NanoLockSpray™ source enclosure, you must slide the sprayer platform out of the source enclosure before you open the enclosure.

5. Pull the source enclosure release (located at the bottom, right-hand side) outwards, and swing open the enclosure.
6. If a corona pin is fitted, use the needle-nose pliers to remove it.

Tip: Store the corona pin in a location where it will not be damaged.

7. Using two hands, grasp the source enclosure, and lift it vertically off the two supporting studs on the source adaptor housing.

Removing the source enclosure:

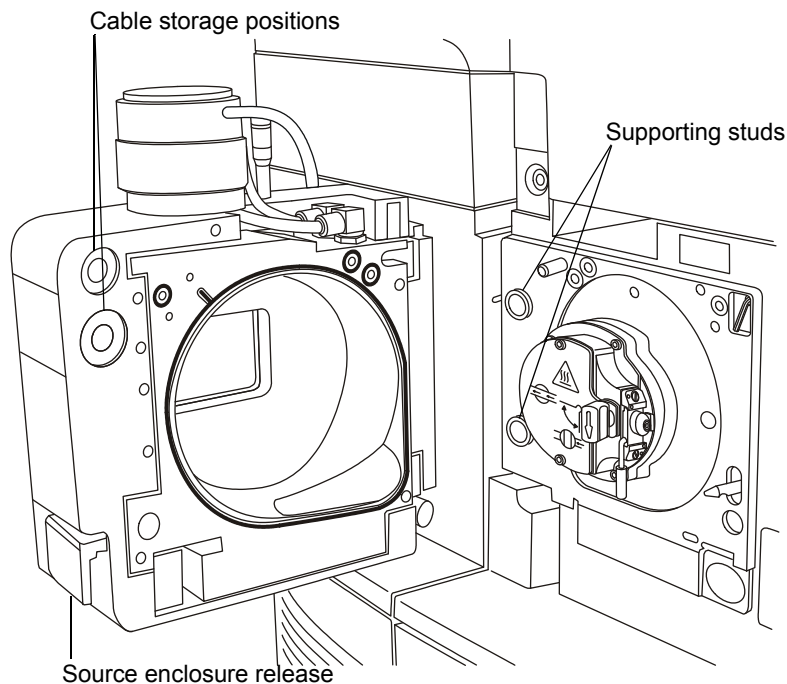

8. Store the cables neatly by plugging them into the cable storage positions on the rear of the source enclosure.

Preparing the source ion block for GC operation

Required materials

- Chemical-resistant, powder-free gloves
- Combined, 2.5-mm Allen wrench and cone extraction tool



Warning: To avoid personal contamination with biologically hazardous, toxic, or corrosive materials, and to avoid spreading contamination to uncontaminated surfaces, wear clean, chemical-resistant, powder-free gloves when working with the source components.



Warning: To avoid burn injuries, take great care while working with the source components, which can be hot.

Preparing the source ion block for GC operation:

1. Close the source isolation valve.
2. Grasp the cone gas nozzle handle, and move it from the vertical to the horizontal position, to rotate the sampling cone assembly by 90°.

Rotating the sampling cone assembly:

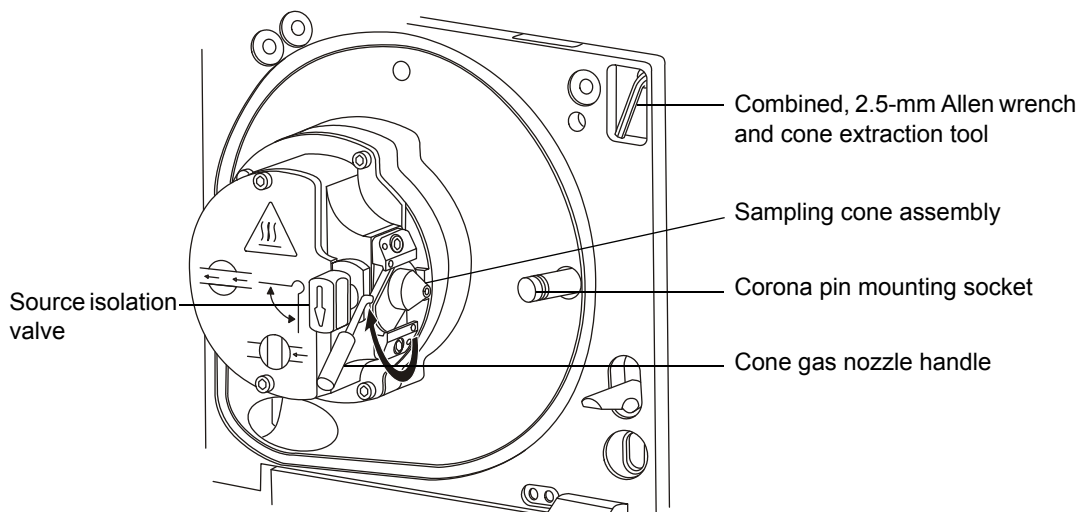



Notice: To avoid damaging the instrument by sudden venting, do not open the source isolation valve at any time while the sampling cone assembly is removed from the ion block assembly.

3. Slide the sampling cone assembly out of the ion block assembly.

Removing the sampling cone assembly:

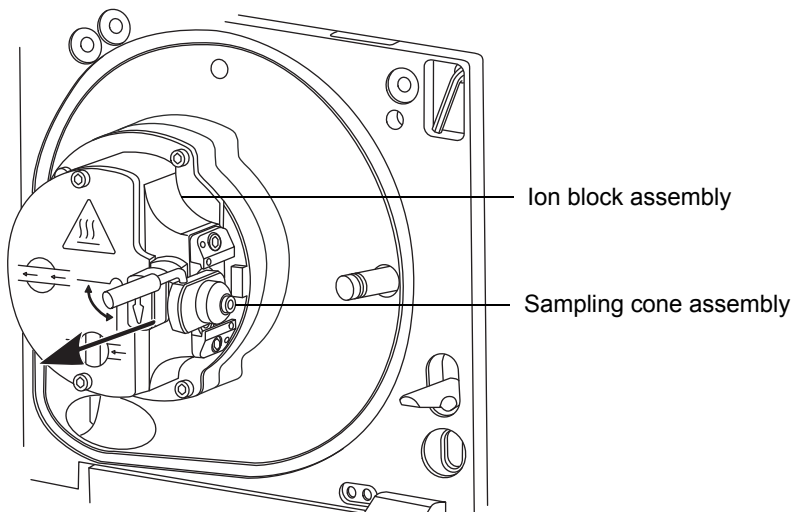

4. Retrieve the combined, 2.5-mm Allen wrench and cone extraction tool from its storage location on the source adaptor housing.
5. Slide the collar to the end of the tool.

Preparing the cone extraction tool:

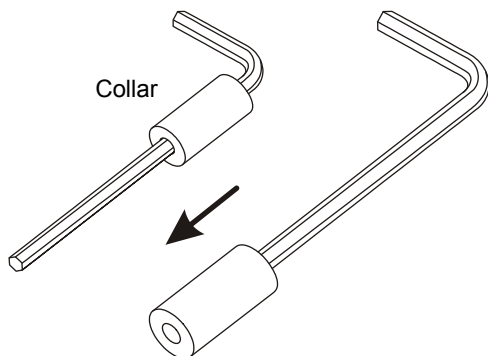

6. Insert the collar into the sample cone.

Inserting the collar into the sample cone:

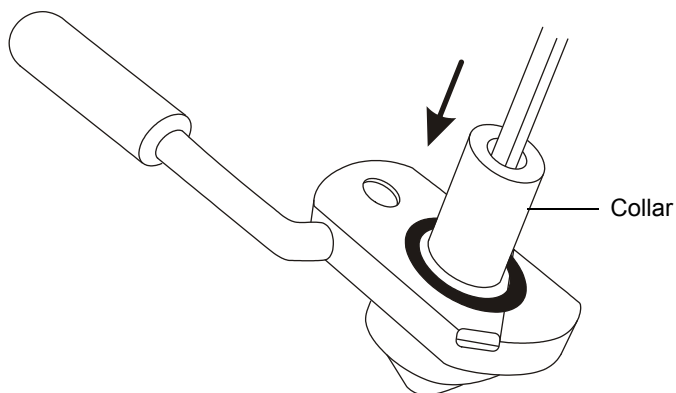

Notice: To avoid damaging the fragile sample cone, do not place it on its tip; instead, place it on its flanged base.

7. Rotate and lift the tool and collar to remove the sample cone from the cone gas nozzle.

Tip: Store the cone gas nozzle in a safe location.

Removing the sample cone:

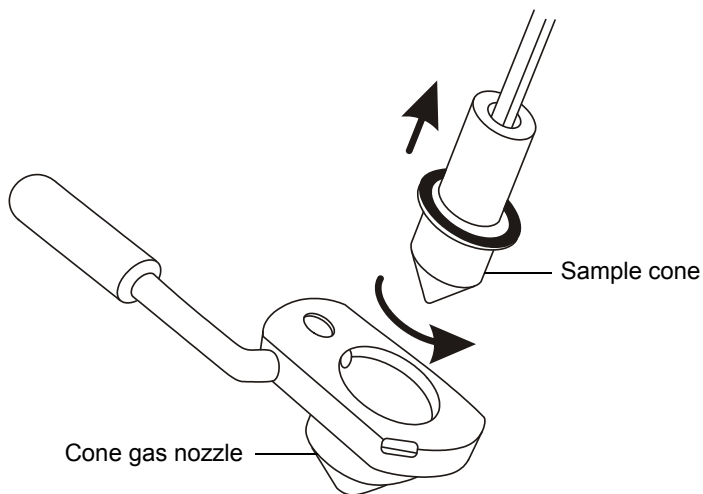

8. Remove the sample cone from the tool.

Tip: If you are using a Xevo TQD or SQ Detector 2 instrument, store the sample cone in a safe location. For all other instruments, retain the sample cone for use in the next procedure.

9. Use the combined, 2.5-mm, Allen wrench and cone-extraction tool to remove the securing screw and washers securing the upper, gas-cone position block to the ion block assembly, and then remove the gas-cone position block from the ion block assembly.

Removing the gas-cone position blocks:

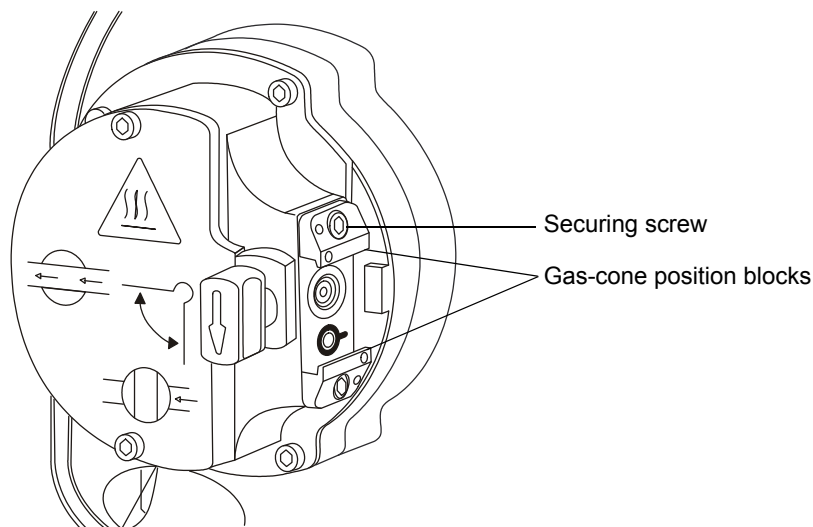

10. Repeat [step 9](#) for the lower, gas-cone position block.
11. Return the tool to its storage location on the source adaptor housing.

Tip: Store the gas-cone position blocks, securing screws, and washers in a safe location.

Installing the APGC ion chamber on the mass spectrometer's ion block

Required materials

- Chemical-resistant, powder-free gloves
- Combined, 2.5-mm Allen wrench and cone extraction tool
- Dentist's mirror



Warning: To avoid personal contamination with biologically hazardous, toxic, or corrosive materials, and to avoid spreading contamination to uncontaminated surfaces, wear clean, chemical-resistant, powder-free gloves when installing the ion chamber.



Warning: To avoid burn injuries, take great care while working with the source components, which can be hot.

Requirement: During APGC operation with the Xevo TQD or SQ Detector 2 mass spectrometer, you must use the reduced-aperture, 0.36-mm, sample cone supplied with the APGC, to avoid problems associated with unstable signal intensity.

To install the APGC ion chamber:

1. Select the correct sample cone for the instrument you intend to use with the APGC:
 - For Xevo TQD or SQ Detector 2 instruments, use the 0.36-mm sample cone provided with the APGC. The cone is labelled “0.36mm” on its base and side wall.
 - For all other instruments, use the sample cone that you retained in the previous procedure ([page 34](#), [step 8](#))
2. Ensure that the O-ring is in position on the sample cone.

2 Setting up the APGC

3. Slide the sample cone into the left-hand end of the APGC ion chamber.

Inserting the sample cone:

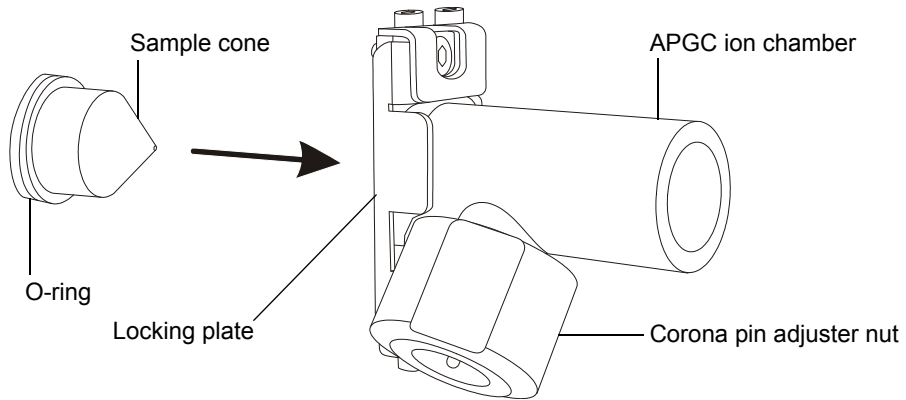

4. Looking into the right-hand end of the APGC ion chamber, use the corona pin adjuster nut to position the corona pin tip to the edge of the small hole at the opposite end of the assembly.

Positioning the corona pin:

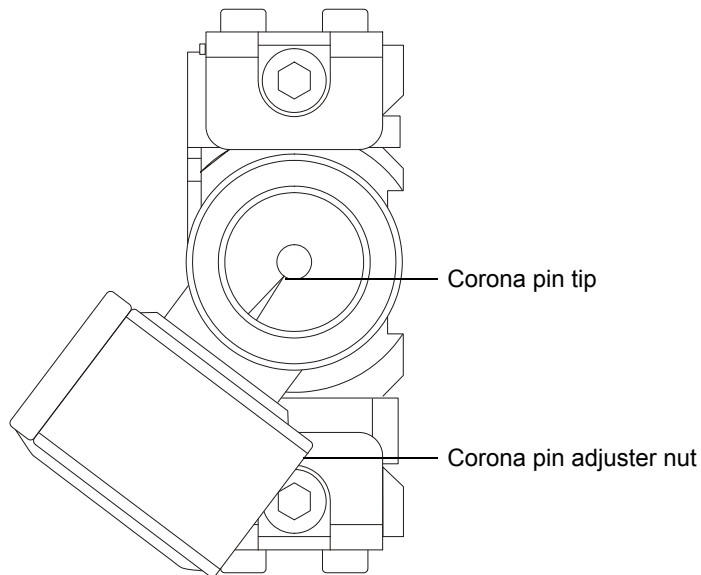

5. Remove the blanking plug from the corona pin mounting socket.
6. Ensure that the source isolation valve is closed.
7. Connect the APGC corona pin extension cable to the corona pin mounting socket.
8. Pull out the locking plate on the APGC ion chamber to expose the 2 captive securing screws.
9. Locate the APGC ion chamber on the ion block and use the combined, 2.5-mm Allen wrench and cone extraction tool to tighten the 2 captive securing screws.
10. Push the locking plate back into position.

Fitting the APGC ion chamber:

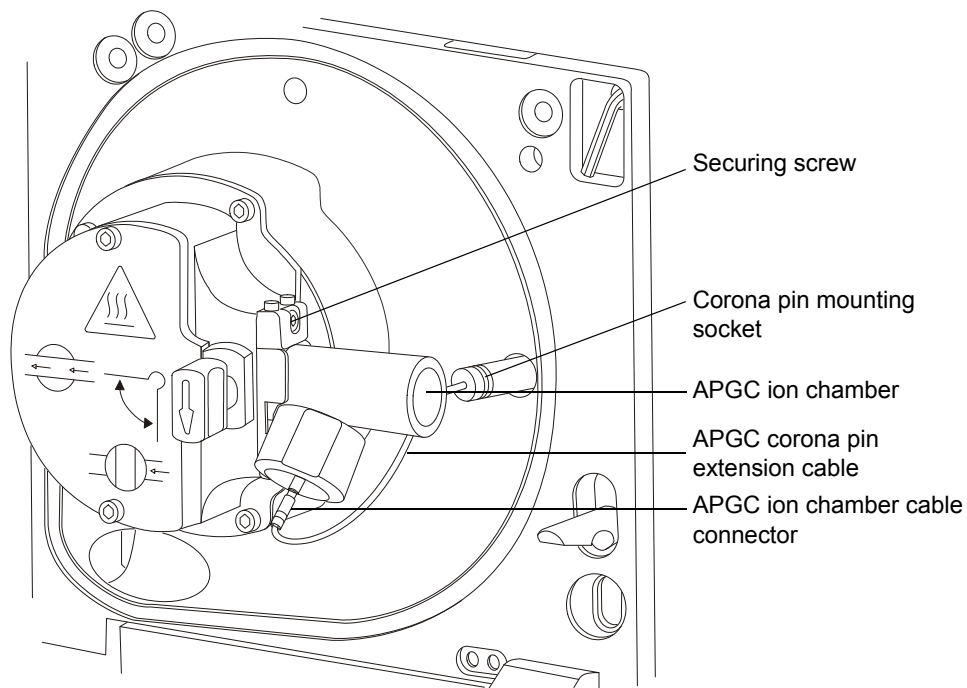

2 Setting up the APGC

11. Connect the free end of the APGC corona pin extension cable to the APGC ion chamber cable connector.
12. Use the dentist's mirror to look into the open end of the APGC ion chamber.

Tip: If necessary, use the corona pin adjuster nut to reposition the corona pin tip to the edge of the small hole at the opposite end of the assembly (see the figure on [page 36](#)).

Installing the APGC source enclosure in the mass spectrometer

Required materials

Chemical-resistant, powder-free gloves



Warning: To avoid personal contamination with biologically hazardous, toxic, or corrosive materials, and to avoid spreading contamination to uncontaminated surfaces, wear clean, chemical-resistant, powder-free gloves when installing the source enclosure.



Warning: To avoid burn injuries, take great care while working with the source components, which can be hot.

To install the APGC source enclosure:

1. Using two hands, fit the source enclosure to the two supporting studs on the source adaptor housing.
2. Connect the source interface cable to the instrument's connector.
3. Slide closed the instrument's source interface door.

Installing the APGC vial carriers in the mass spectrometer's source

Required materials

Chemical-resistant, powder-free gloves



Warning: To avoid personal contamination with biologically hazardous, toxic, or corrosive materials, and to avoid spreading contamination to uncontaminated surfaces, wear clean, chemical-resistant, powder-free gloves when handling source components.



Warning: To avoid burn injuries, take great care while working with the source components, which can be hot.

To install the vial carriers in the mass spectrometer's source:

1. Fit the heated vial carrier on top of the mass spectrometer's source ion block.
2. Fit the unheated vial carrier into the bottom of the APGC source enclosure; push it fully to the front of the enclosure.
3. Open the source isolation valve.
4. Swing the source enclosure closed.

Vial carrier locations:

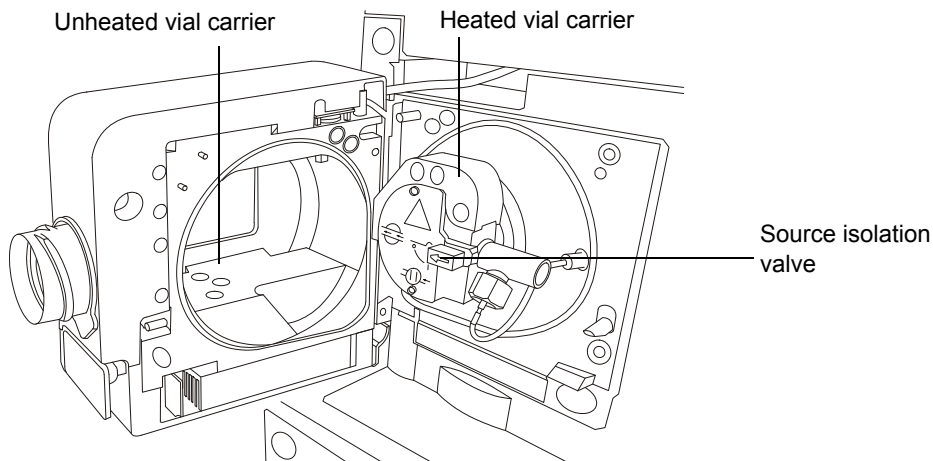

Installing vials in the vial carriers

You must install the vials in the vial carriers before connecting the APGC to the mass spectrometer (see [page 42](#)).

Required materials

- Chemical-resistant, powder-free gloves
- Tweezers



Warning: To avoid personal contamination with biologically hazardous, toxic, or corrosive materials, and to avoid spreading contamination to uncontaminated surfaces, wear clean, chemical-resistant, powder-free gloves when handling source components.



Warning: To avoid electric shock, prepare the instrument for work performed on its source before beginning this procedure.

To install the vials in the vial carriers:

1. Prepare the instrument for working on its source (see [page 28](#)).



Warning: To avoid burn injuries, take great care while working with the source components, which can be hot.

2. Prepare the sample vials as required (see [Appendix C](#)).
3. Pull the APGC source enclosure release (located at the bottom, right-hand side) outwards, and swing open the enclosure.

4. Use tweezers to insert the vials into the holes in the vial carriers.

Requirement: You must use only closed vials when placing samples in the heated vial carrier.

Tips:

- Use the unheated vial carrier for more volatile samples, the heated vial carrier for less volatile samples.
 - Multiple vial holes are provided for flexibility when introducing reference and modifier materials.
5. Swing the source enclosure closed.

Connecting the APGC to the mass spectrometer

Required materials

Chemical-resistant, powder-free gloves



Warning: To avoid personal contamination with biologically hazardous, toxic, or corrosive materials, and to avoid spreading contamination to uncontaminated surfaces, wear clean, chemical-resistant, powder-free gloves when handling source components.



Warning: To avoid burn injuries, take great care while working with the APGC source and the heated transfer line assembly; they can be hot.

To connect the APGC to the mass spectrometer:

1. Unscrew and remove the APGC protection cap covering the capillary column tip (see the figure on [page 22](#)).
2. With one hand, support the heated transfer line assembly under the locking ring.
3. Pull the locking handle toward you to release the sliding table, then carefully move the sliding table towards the mass spectrometer (see the figure on [page 18](#)).
4. Engage the screw threads on the APGC locking ring and source enclosure heated transfer line connector (see the figures on [page 22](#) and [page 23](#)).

Tip: You sometimes must carefully maneuver these components to align the APGC locking ring and source enclosure heated transfer line connector correctly.

5. Turn the locking ring fully clockwise (by raising its handle), until it is fully engaged with the source enclosure's heated transfer line connector.
6. When the locking ring is fully engaged, release the locking handle to lock the sliding table.

Disconnecting the APGC from the mass spectrometer

Required materials

Chemical-resistant, powder-free gloves



Warning: To avoid personal contamination with biologically hazardous, toxic, or corrosive materials, and to avoid spreading contamination to uncontaminated surfaces, wear clean, chemical-resistant, powder-free gloves when handling source components.



Warning: To avoid burn injuries, take great care while working with the APGC source and the heated transfer line assembly; they can be hot.

To disconnect the APGC from the mass spectrometer:

1. Pull the locking handle outward to unlock the sliding table (see the figure on [page 18](#)).
2. Turn the locking ring fully counterclockwise to disengage the screw threads from the source enclosure's heated transfer line connector.
3. Carefully move the sliding table fully away from the mass spectrometer.
4. Release the locking handle to secure the sliding table.
5. Fit and tighten the APGC protection cap over the capillary column tip.

Removing vials from the vial carriers

You must disconnect the APGC from the mass spectrometer before removing vials from the vial carriers (see [page 43](#)).

Required materials

- Chemical-resistant, powder-free gloves
- Tweezers



Warning: To avoid personal contamination with biologically hazardous, toxic, or corrosive materials, and to avoid spreading contamination to uncontaminated surfaces, wear clean, chemical-resistant, powder-free gloves when handling source components.



Warning: To avoid electric shock, prepare the instrument for work performed on its source (see [page 28](#)) before removing vials from the vial carriers.

To remove vials from the vial carriers:

1. Prepare the instrument for working on its source (see [page 28](#)).



Warning: To avoid burn injuries, take great care while working with the source and vials; they can be hot.

2. Pull the APGC source enclosure release (located at the bottom, right-hand side) outward, and then swing open the enclosure.
3. Use the tweezers to remove the vials from the vial carriers.
4. Swing the source enclosure closed.

Preparing the mass spectrometer for LC operation

For additional information, see the mass spectrometer's operator's overview and maintenance guide.

Removing the APGC vial carriers from the mass spectrometer's source

Required materials

Chemical-resistant, powder-free gloves



Warning: To avoid personal contamination with biologically hazardous, toxic, or corrosive materials, and to avoid spreading contamination to uncontaminated surfaces, wear clean, chemical-resistant, powder-free gloves when handling source components.



Warning: To avoid electric shock, prepare the instrument for work performed on its source before removing the vial carriers from the mass spectrometer's source.

To remove the vial carriers:

1. Prepare the instrument for working on its source (see [page 28](#)).



Warning: To avoid burn injuries, take great care while working with the source and heated vial carrier; they can be hot.

2. Pull the APGC source enclosure release (located at the bottom, right-hand side) outward, and then swing open the enclosure.
3. Close the source isolation valve.
4. Remove the heated vial carrier from the top of the mass spectrometer's source ion block (see the figure on [page 24](#)).
5. Remove the unheated vial carrier from the bottom of the source enclosure.

Removing the APGC source enclosure from the mass spectrometer

Required materials

Chemical-resistant, powder-free gloves



Warning: To avoid personal contamination with biologically hazardous, toxic, or corrosive materials, and to avoid spreading contamination to uncontaminated surfaces, wear clean, chemical-resistant, powder-free gloves when handling source components.



Warning: To avoid burn injuries, take great care while working with the source components, which can be hot.

To remove the APGC source enclosure:

1. Slide open the source's interface door.
2. Disconnect the source interface cable from the connector on the instrument.
3. Using two hands, grasp the source enclosure, and lift it vertically off the two supporting studs on the source adaptor housing.

Removing the APGC ion chamber from the mass spectrometer's ion block

Required materials

- Chemical-resistant, powder-free gloves
- Combined, 2.5-mm Allen wrench and cone extraction tool



Warning: To avoid personal contamination with biologically hazardous, toxic, or corrosive materials, and to avoid spreading contamination to uncontaminated surfaces, wear clean, chemical-resistant, powder-free gloves when handling source components.



Warning: To avoid burn injuries, take great care while working with the source components, which can be hot.



Notice: To avoid damaging the instrument by sudden venting, do not open the source isolation valve at any time while the APGC ion chamber is removed from the ion block assembly.

To remove the APGC ion chamber:

1. Disconnect the APGC corona pin extension cable from the APGC ion chamber cable connector (see [page 37](#)).
2. Pull out the locking plate on the APGC ion chamber to expose the 2 captive screws (see [page 36](#)).
3. Use the combined, 2.5-mm Allen wrench and cone extraction tool to loosen the 2 captive screws that secure the APGC ion chamber to the ion block.
4. Remove the APGC ion chamber from the ion block.
5. Disconnect the APGC corona pin extension cable from the corona pin mounting socket.
6. Slide the sample cone, with its O-ring, out of the left-hand end of the APGC ion chamber.

Tip: If you are using a Xevo TQD or SQ Detector 2 instrument, store the sample cone (labelled “0.36mm” on its base and side wall) in a safe

location. For all other instruments, retain the sample cone for use in the next procedure.

Store all other APGC components in a safe location.

Preparing the source ion block for LC operation

Required materials

- Chemical-resistant, powder-free gloves
- Combined, 2.5-mm Allen wrench and cone extraction tool



Warning: To avoid personal contamination with biologically hazardous, toxic, or corrosive materials, and to avoid spreading contamination to uncontaminated surfaces, wear clean, chemical-resistant, powder-free gloves when handling source components.



Warning: To avoid burn injuries, take great care while working with the source components, which can be hot.



Notice: To avoid damaging the instrument by sudden venting, do not open the source isolation valve before the sampling cone assembly is securely fitted to the ion block assembly.

Requirement: During LC operation with the Xevo TQD or SQ Detector 2 instrument, you must use the original, 0.50-mm, sample cone supplied with the instrument, to avoid problems associated with low sensitivity.

To prepare the source ion block for LC operation:

1. Use the 2.5-mm, combined Allen wrench and cone extraction tool to fit and tighten the screw and washers securing the upper, gas-cone position block to the ion block assembly (see [page 34](#)).
2. Repeat [step 1](#) for the lower, gas-cone position block.

3. Select the correct sample cone for your instrument:
 - For the Xevo TQD or SQ Detector 2 instruments, use the 0.50-mm sample cone, supplied with the instrument, which you stored when preparing the source ion block for GC operation (see [page 34, step 8](#)).
 - For all other instruments, use the sample cone that you retained in the previous procedure ([page 47, step 6](#)).
4. Carefully slide the sample cone, including its O-ring, into the cone gas nozzle.
5. Hold the sampling cone assembly so that the cone gas nozzle handle is oriented horizontally and at the top, and then slide the sampling cone assembly into the ion block assembly.
6. Grasp the cone gas nozzle handle, and then move the handle downward from the horizontal to the vertical position to rotate the sampling cone assembly by 90° degrees (see [page 31](#)).
7. Open the source isolation valve.

Installing the LC source enclosure on the instrument

Required materials

Chemical-resistant, powder-free gloves



Warning: To avoid personal contamination with biologically hazardous, toxic, or corrosive materials, and to avoid spreading contamination to uncontaminated surfaces, wear clean, chemical-resistant, powder-free gloves when handling source components.

To install the LC source enclosure on the instrument:

1. Using two hands, fit the source enclosure to the two supporting studs on the source adaptor housing.



Notice: To avoid damaging the sample inlet when installing a NanoLockSpray source enclosure, slide the sprayer platform out of the source enclosure before closing it.

2. Swing the source enclosure closed.
3. Slide open the instrument's source interface door.
4. Connect the source enclosure cables to the instrument's connectors.
Tip: The cables and connectors are color-coded; the blue-sleeved cable connects to the blue connector and the yellow-sleeved cable to the yellow connector.
5. Slide the instrument's source interface door closed.

3

Maintenance Procedures

This chapter provides the maintenance guidelines and procedures necessary to maintain the APGC's performance.

Keep to a maintenance schedule, and perform maintenance as required and described in this chapter.

Contents:

Topic	Page
Maintenance schedule	52
Spare parts	52
Safety and handling	53
Cleaning the mass spectrometer sample cone.....	54
Cleaning or replacing the corona pin	54
Cleaning the APGC ion chamber	57

Maintenance schedule

The following table lists periodic maintenance schedules that ensure optimum instrument performance.

Maintenance schedule:

Procedure	Frequency	For information...
Clean the mass spectrometer sample cone.	When sensitivity decreases to unacceptable levels.	See page 54 .
Clean or replace the corona pin.	When the corona pin is corroded or black, or the sensitivity decreases to unacceptable levels.	See page 54 .
Clean the APGC ion chamber	When sensitivity decreases to unacceptable levels.	See page 57 .

Spare parts

Waters recommends that you replace only the parts mentioned in this document. For spare parts details, see the Waters Quality Parts Locator on the Waters Web site's Services/Support page.

Safety and handling

Bear in mind the following safety considerations when performing maintenance procedures:



Warning: The instrument components can be contaminated with biologically hazardous materials. Always wear chemical-resistant, powder-free gloves while handling the components.



Warning: To prevent injury, always observe Good Laboratory Practices when handling solvents, changing tubing, or operating the instrument. Know the physical and chemical properties of the solvents used (see the Material Safety Data Sheets for the solvents in use).



Warning: To avoid electric shock, do not remove the instrument's panels. The panels do not cover user-serviceable components.



Warning: To avoid electric shock, ensure that the instrument is in Standby mode before performing any maintenance activity.



Warning: To avoid burn injuries, take great care while working with the probe and source; they can be hot.



Warning: To avoid injury, ensure that these criteria are met when performing maintenance inside the source enclosure:

- The instrument is in Standby mode, and the auxiliary gas flow (API gas) is turned off (see [page 28](#)).
- The APGC is disconnected from the instrument (see [page 43](#)).
- The APGC protection cap is fitted to the capillary column tip (see [page 22](#)).

See [Appendix A](#) for safety advisory information.

If you are working on the GC equipment, refer to the relevant manufacturer's user documentation.

Cleaning the mass spectrometer sample cone

For details about how to clean the sample cone, refer to the mass spectrometer's operator's overview and maintenance guide.

Cleaning or replacing the corona pin

APGC ion chamber assembly:

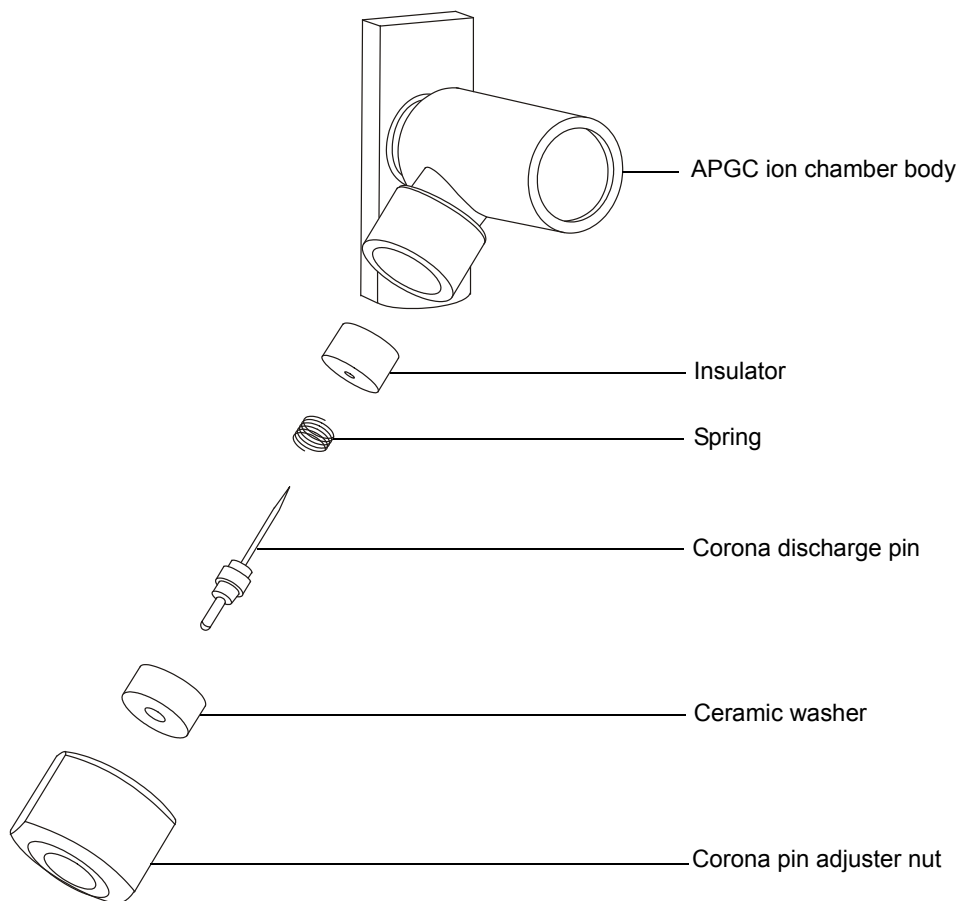

Required materials

- Chemical-resistant, powder-free gloves
- Needle-nose pliers
- HPLC-grade (or better) methanol
- Lint-free tissue
- Lapping film
- New corona pin



Warning: To avoid personal contamination with biologically hazardous, toxic, or corrosive materials, and to avoid spreading contamination to uncontaminated surfaces, wear clean, chemical-resistant, powder-free gloves when working with probe and source components.



Warning: To avoid electric shock, prepare the instrument for work performed on its source before beginning this procedure.



Warning: To avoid puncture wounds, handle the corona pin with care.

To clean or replace the corona pin:

1. Prepare the instrument for working on its source (see [page 28](#)).



Warning: To avoid burn injuries, take great care while working with the probe and source; they can be hot.

2. Pull the source enclosure release (located at the bottom, right-hand side) outwards, and then swing open the enclosure.
3. Disconnect the APGC corona pin extension cable from the cable connector of the APGC ion chamber.

Important: Do not lose any of the internal components of the APGC ion chamber when removing the corona pin adjuster nut from the assembly.

4. Remove the APGC ion chamber from the ion block (see [page 47](#)).

Recommendation: Clean the APGC ion chamber after it has been removed (see [page 57](#)).

5. Carefully unscrew the corona pin adjuster nut and remove it, together with the corona pin assembly, from the APGC ion chamber (see the figure on [page 54](#)).
6. Remove the ceramic washer, spring, and insulator from the corona pin assembly.
7. Replace the corona pin if it is deformed or otherwise damaged.

Tip: If it is undamaged, clean the tip of the pin with the lapping film, and then wipe it clean with a methanol-saturated lint-free tissue.



Warning: To avoid spreading contamination, dispose of the corona pin in accordance with local environmental regulations.

8. If you are replacing the corona pin, dispose of the old pin in accordance with local environmental regulations.
9. Fit the ceramic washer, spring, and insulator to the corona pin (see the figure on [page 54](#)).
10. Fit the corona pin assembly in the APGC ion chamber, and fit and tighten the corona pin adjuster nut.
11. Reposition the corona pin (see the figure on [page 36](#)).
12. Refit the APGC ion chamber onto the ion block (see the figure on [page 37](#)).
13. Connect the APGC corona pin extension cable to the corona pin mounting socket.
14. Close the source enclosure.

Cleaning the APGC ion chamber

Required materials

- Chemical-resistant, powder-free gloves
- Combined, 2.5-mm Allen wrench and cone extraction tool
- HPLC-grade (or better) methanol
- Lint-free tissue



Warning: To avoid personal contamination with biologically hazardous, toxic, or corrosive materials, wear clean, chemical-resistant, powder-free gloves when working with probe and source components.



Warning: To avoid burn injuries, take great care while working with the source components, which can be hot.



Notice: To avoid damaging the instrument by sudden venting, do not open the source isolation valve at any time while the APGC ion chamber is removed from the ion block assembly.

To clean the APGC ion chamber:

1. Prepare the instrument for working on its source (see [page 28](#)).
2. Remove the APGC ion chamber (see [page 47](#)).
3. Apply methanol to the lint-free tissue, and use it to carefully clean the ion chamber.
4. Refit the APGC ion chamber onto the ion block (see [page 35](#)).

A Safety Advisories

Waters instruments display hazard symbols designed to alert you to the hidden dangers of operating and maintaining the instruments. Their corresponding user guides also include the hazard symbols, with accompanying text statements describing the hazards and telling you how to avoid them. This appendix presents all the safety symbols and statements that apply to the entire line of Waters products.

Contents:

Topic	Page
Warning symbols.....	60
Notices	64
Warnings that apply to all Waters instruments and devices	65
If the fuse types and ratings do not appear on the instrument:....	71

Warning symbols

Warning symbols alert you to the risk of death, injury, or seriously adverse physiological reactions associated with an instrument's use or misuse. Heed all warnings when you install, repair, and operate Waters instruments. Waters assumes no liability for the failure of those who install, repair, or operate its instruments to comply with any safety precaution.

Task-specific hazard warnings

The following warning symbols alert you to risks that can arise when you operate or maintain an instrument or instrument component. Such risks include burn injuries, electric shocks, ultraviolet radiation exposures, and others.

When the following symbols appear in a manual's narratives or procedures, their accompanying text identifies the specific risk and explains how to avoid it.



Warning: (General risk of danger. When this symbol appears on an instrument, consult the instrument's user documentation for important safety-related information before you use the instrument.)



Warning: (Risk of burn injury from contacting hot surfaces.)



Warning: (Risk of electric shock.)



Warning: (Risk of fire.)



Warning: (Risk of sharp-point puncture injury.)



Warning: (Risk of injury caused by moving machinery.)



Warning: (Risk of hand crush injury.)



Warning: (Risk of exposure to ultraviolet radiation.)



Warning: (Risk of contacting corrosive substances.)



Warning: (Risk of exposure to a toxic substance.)



Warning: (Risk of personal exposure to laser radiation.)



Warning: (Risk of exposure to biological agents that can pose a serious health threat.)



Warning: (Risk of tipping.)



Warning: (Risk of explosion.)



Warning: (Risk of eye injury.)

Specific warnings

The following warnings can appear in the user manuals of particular instruments and on labels affixed to them or their component parts.

Burst warning

This warning applies to Waters instruments fitted with nonmetallic tubing.



Warning: Pressurized nonmetallic, or polymer, tubing can burst. Observe these precautions when working around such tubing:

- Wear eye protection.
- Extinguish all nearby flames.
- Do not use tubing that is, or has been, stressed or kinked.
- Do not expose nonmetallic tubing to incompatible compounds like tetrahydrofuran (THF) and nitric or sulfuric acids.
- Be aware that some compounds, like methylene chloride and dimethyl sulfoxide, can cause nonmetallic tubing to swell, which significantly reduces the pressure at which the tubing can rupture.

Mass spectrometer shock hazard

The following warning applies to all Waters mass spectrometers.



Warning: To avoid electric shock, do not remove the mass spectrometer's protective panels. The components they cover are not user-serviceable.

The following warning applies to certain mass spectrometers when they are in Operate mode.



Warning: To avoid nonlethal electric shock, ensure the mass spectrometer is in Standby mode before you touch any of its external surfaces that are marked with this high voltage warning symbol.

Mass spectrometer flammable solvents warning

This warning applies to mass spectrometers performing an analysis that requires the use of flammable solvents.



Warning: To prevent ignition of flammable solvent vapors in the enclosed space of a mass spectrometer's ion source, ensure that nitrogen flows continuously through the source. The nitrogen supply pressure must not fall below 400 kPa (4 bar, 58 psi) during an analysis requiring the use of flammable solvents. Also a gas-fail device must be installed, to interrupt the flow of LC solvent should the nitrogen supply fail.

Biohazard warning

The following warning applies to Waters instruments and devices that can process material containing biohazards, which are substances that contain biological agents capable of producing harmful effects in humans.



Warning: To avoid infection with potentially infectious, human-sourced products, inactivated microorganisms, and other biological materials, assume that all biological fluids that you handle are infectious.

Specific precautions appear in the latest edition of the US National Institutes of Health (NIH) publication, *Biosafety in Microbiological and Biomedical Laboratories (BMBL)*.

Observe Good Laboratory Practice (GLP) at all times, particularly when working with hazardous materials, and consult your the biohazard safety representative for your organization regarding the proper use and handling of infectious substances.

Biohazard and chemical hazard warning

This warning applies to Waters instruments and devices that can process biohazards, corrosive materials, or toxic materials.



Warning: To avoid personal contamination with biohazards, toxic materials, or corrosive materials, you must understand the hazards associated with their handling.

Guidelines prescribing the proper use and handling of such materials appear in the latest edition of the National Research Council's publication, *Prudent Practices in the Laboratory: Handling and Disposal of Chemicals*.

Observe Good Laboratory Practice (GLP) at all times, particularly when working with hazardous materials, and consult the safety representative for your organization regarding its protocols for handling such materials.

Notices

Notices appear where an instrument or device can be subject to use or misuse that can damage it or compromise a sample's integrity. The exclamation point symbol and its associated statement alert you to such risk.

- ! **Notice:** To avoid damaging the instrument's case, do not clean it with abrasives or solvents.

Prohibition symbol

Prohibition symbols signify an action you must not perform under any circumstances. The following symbol and its associated statement indicates a prohibited action that applies to the instrument.



Prohibited: Do not place containers on top of the instrument or on its front covers. Instead, use the bottle tray.

Warnings that apply to all Waters instruments and devices

When operating this device, follow standard quality-control procedures and the equipment guidelines in this section.



Attention: Changes or modifications to this unit not expressly approved by the party responsible for compliance could void the user's authority to operate the equipment.

Important: Toute modification sur cette unité n'ayant pas été expressément approuvée par l'autorité responsable de la conformité à la réglementation peut annuler le droit de l'utilisateur à exploiter l'équipement.

Achtung: Jedwede Änderungen oder Modifikationen an dem Gerät ohne die ausdrückliche Genehmigung der für die ordnungsgemäße Funktionstüchtigkeit verantwortlichen Personen kann zum Entzug der Bedienungsbefugnis des Systems führen.

Avvertenza: qualsiasi modifica o alterazione apportata a questa unità e non espressamente autorizzata dai responsabili per la conformità fa decadere il diritto all'utilizzo dell'apparecchiatura da parte dell'utente.

Atencion: cualquier cambio o modificación efectuado en esta unidad que no haya sido expresamente aprobado por la parte responsable del cumplimiento puede anular la autorización del usuario para utilizar el equipo.

注意: 未經有關法規認證部門允許對本設備進行的改變或修改,可能會使使用者喪失操作該設備的權利。

注意: 未經有關法規認證部門明確允許對本設備進行的改變或改裝,可能會使使用者喪失操作該設備的合法性。

주의: 규정 준수를 책임지는 당사자의 명백한 승인 없이 이 장치를 개조 또는 변경할 경우, 이 장치를 운용할 수 있는 사용자 권한의 효력을 상실할 수 있습니다.

注意: 規制機関から明確な承認を受けずに本装置の変更や改造を行うと、本装置のユーザーとしての承認が無効になる可能性があります。



Warning: Use caution when working with any polymer tubing under pressure:

- Always wear eye protection when near pressurized polymer tubing.
- Extinguish all nearby flames.
- Do not use tubing that has been severely stressed or kinked.
- Do not use nonmetallic tubing with tetrahydrofuran (THF) or concentrated nitric or sulfuric acids.
- Be aware that methylene chloride and dimethyl sulfoxide cause nonmetallic tubing to swell, which greatly reduces the rupture pressure of the tubing.

Attention: Manipulez les tubes en polymère sous pression avec précaution:

- Portez systématiquement des lunettes de protection lorsque vous vous trouvez à proximité de tubes en polymère pressurisés.
- Éteignez toute flamme se trouvant à proximité de l'instrument.
- Évitez d'utiliser des tubes sévèrement déformés ou endommagés.
- Évitez d'utiliser des tubes non métalliques avec du tétrahydrofurane (THF) ou de l'acide sulfurique ou nitrique concentré.
- Sachez que le chlorure de méthylène et le diméthylesulfoxyde entraînent le gonflement des tuyaux non métalliques, ce qui réduit considérablement leur pression de rupture.

Vorsicht: Bei der Arbeit mit Polymerschläuchen unter Druck ist besondere Vorsicht angebracht:

- In der Nähe von unter Druck stehenden Polymerschläuchen stets Schutzbrille tragen.
- Alle offenen Flammen in der Nähe löschen.
- Keine Schläuche verwenden, die stark geknickt oder überbeansprucht sind.
- Nichtmetallische Schläuche nicht für Tetrahydrofuran (THF) oder konzentrierte Salpeter- oder Schwefelsäure verwenden.
- Durch Methylenchlorid und Dimethylsulfoxid können nichtmetallische Schläuche quellen; dadurch wird der Berstdruck des Schlauches erheblich reduziert.



Attenzione: fare attenzione quando si utilizzano tubi in materiale polimerico sotto pressione:

- Indossare sempre occhiali da lavoro protettivi nei pressi di tubi di polimero pressurizzati.
- Spegnerle tutte le fiamme vive nell'ambiente circostante.
- Non utilizzare tubi eccessivamente logorati o piegati.
- Non utilizzare tubi non metallici con tetraidrofurano (THF) o acido solforico o nitrico concentrati.
- Tenere presente che il cloruro di metilene e il dimetilsolfossido provocano rigonfiamenti nei tubi non metallici, riducendo notevolmente la pressione di rottura dei tubi stessi.

Advertencia: se recomienda precaución cuando se trabaje con tubos de polímero sometidos a presión:

- El usuario deberá protegerse siempre los ojos cuando trabaje cerca de tubos de polímero sometidos a presión.
- Si hubiera alguna llama las proximidades.
- No se debe trabajar con tubos que se hayan doblado o sometido a altas presiones.
- Es necesario utilizar tubos de metal cuando se trabaje con tetrahidrofurano (THF) o ácidos nítrico o sulfúrico concentrados.
- Hay que tener en cuenta que el cloruro de metileno y el sulfóxido de dimetilo dilatan los tubos no metálicos, lo que reduce la presión de ruptura de los tubos.

警告: 當在有壓力的情況下使用聚合物管線時，小心注意以下幾點。

- 當接近有壓力的聚合物管線時一定要戴防護眼鏡。
- 熄滅附近所有的火焰。
- 不要使用已經被壓癟或嚴重彎曲管線。
- 不要在非金屬管線中使用四氫呋喃或濃硝酸或濃硫酸。
- 要了解使用二氯甲烷及二甲基亞楓會導致非金屬管線膨脹，大大降低管線的耐壓能力。



警告: 当有压力的情况下使用管线时, 小心注意以下几点:

- 当接近有压力的聚合物管线时一定要戴防护眼镜。
- 熄灭附近所有的火焰。
- 不要使用已经被压瘪或严重弯曲的管线。
- 不要在非金属管线中使用四氢呋喃或浓硝酸或浓硫酸。
- 要了解使用二氯甲烷及二甲基亚砜会导致非金属管线膨胀, 大大降低管线的耐压能力。

경고: 가압 폴리머 튜브로 작업할 경우에는 주의하십시오.

- 가압 폴리머 튜브 근처에서는 항상 보호 안경을 착용하십시오.
- 근처의 화기를 모두 끄십시오.
- 심하게 변형되거나 꼬인 튜브는 사용하지 마십시오.
- 비금속(Nonmetallic) 튜브를 테트라히드로푸란(Tetrahydrofuran: THF) 또는 농축 질산 또는 황산과 함께 사용하지 마십시오.
- 염화 메틸렌(Methylene chloride) 및 디메틸설폭시드(Dimethyl sulfoxide)는 비금속 튜브를 부풀려 튜브의 파열 압력을 크게 감소시킬 수 있으므로 유의하십시오.

警告: 圧力のかかったポリマーチューブを扱うときは、注意してください。

- 加圧されたポリマーチューブの付近では、必ず保護メガネを着用してください。
- 近くにある火を消してください。
- 著しく変形した、または折れ曲がったチューブは使用しないでください。
- 非金属チューブには、テトラヒドロフラン(THF)や高濃度の硝酸または硫酸などを流さないでください。
- 塩化メチレンやジメチルスルホキシドは、非金属チューブの膨張を引き起こす場合があります、その場合、チューブは極めて低い圧力で破裂します。



Warning: The user shall be made aware that if the equipment is used in a manner not specified by the manufacturer, the protection provided by the equipment may be impaired.

Attention: L'utilisateur doit être informé que si le matériel est utilisé d'une façon non spécifiée par le fabricant, la protection assurée par le matériel risque d'être défectueuses.

Vorsicht: Der Benutzer wird darauf aufmerksam gemacht, dass bei unsachgemäßer Verwendung des Gerätes die eingebauten Sicherheitseinrichtungen unter Umständen nicht ordnungsgemäß funktionieren.

Attenzione: si rende noto all'utente che l'eventuale utilizzo dell'apparecchiatura secondo modalità non previste dal produttore può compromettere la protezione offerta dall'apparecchiatura.

Advertencia: el usuario deberá saber que si el equipo se utiliza de forma distinta a la especificada por el fabricante, las medidas de protección del equipo podrían ser insuficientes.

警告: 使用者必須非常清楚如果設備不是按照製造廠商指定的方式使用，那麼該設備所提供的保護將被削弱。

警告: 使用者必須非常清楚如果設備不是按照製造廠商指定的方式使用，那麼該設備所提供的保護將被削弱。

경고: 제조업체가 명시하지 않은 방식으로 장비를 사용할 경우 장비가 제공하는 보호 수단이 제대로 작동하지 않을 수 있다는 점을 사용자에게 반드시 인식시켜야 합니다.

警告: ユーザーは、製造元により指定されていない方法で機器を使用すると、機器が提供している保証が無効になる可能性があることに注意して下さい。

Warnings that address the replacing of fuses

The following warnings pertain to instruments equipped with user-replaceable fuses.

If the fuse types and ratings appear on the instrument:



Warning: To protect against fire, replace fuses with those of the type and rating printed on panels adjacent to instrument fuse covers.



Attention: pour éviter tout risque d'incendie, remplacez toujours les fusibles par d'autres du type et de la puissance indiqués sur le panneau à proximité du couvercle de la boîte à fusible de l'instrument.



Vorsicht: Zum Schutz gegen Feuer die Sicherungen nur mit Sicherungen ersetzen, deren Typ und Nennwert auf den Tafeln neben den Sicherungsabdeckungen des Geräts gedruckt sind.



Attenzione: per garantire protezione contro gli incendi, sostituire i fusibili con altri dello stesso tipo aventi le caratteristiche indicate sui pannelli adiacenti alla copertura fusibili dello strumento.



Advertencia: Para evitar incendios, sustituir los fusibles por aquellos del tipo y características impresos en los paneles adyacentes a las cubiertas de los fusibles del instrumento.



警告: 為了避免火災，更換保險絲時，請使用與儀器保險絲蓋旁面板上所印刷之相同類型與規格的保險絲。



警告: 为了避免火灾，应更换与仪器保险丝盖旁边面板上印刷的类型和规格相同的保险丝。



경고: 화재의 위험을 막으려면 기기 퓨즈 커버에 가까운 패널에 인쇄된 것과 동일한 타입 및 정격의 제품으로 퓨즈를 교체하십시오.



警告: 火災予防のために、ヒューズ交換では機器ヒューズカバー脇のパネルに記載されているタイプおよび定格のヒューズをご使用ください。

If the fuse types and ratings do not appear on the instrument:



Warning: To protect against fire, replace fuses with those of the type and rating indicated in the “Replacing fuses” section of the Maintenance Procedures chapter.



Attention: pour éviter tout risque d'incendie, remplacez toujours les fusibles par d'autres du type et de la puissance indiqués dans la rubrique "Remplacement des fusibles" du chapitre traitant des procédures de maintenance.



Vorsicht: Zum Schutz gegen Feuer die Sicherungen nur mit Sicherungen ersetzen, deren Typ und Nennwert im Abschnitt "Sicherungen ersetzen" des Kapitels "Wartungsverfahren" angegeben sind.



Attenzione: per garantire protezione contro gli incendi, sostituire i fusibili con altri dello stesso tipo aventi le caratteristiche indicate nel paragrafo "Sostituzione dei fusibili" del capitolo "Procedure di manutenzione".



Advertencia: Para evitar incendios, sustituir los fusibles por aquellos del tipo y características indicados en la sección "Sustituir fusibles".



警告: 為了避免火災，更換保險絲時，應使用「維護步驟」章節中「更換保險絲」所指定之相同類型與規格的保險絲。



警告: 为了避免火灾，应更换“维护步骤”一章的“更换保险丝”一节中介绍的相同类型和规格的保险丝。



경고: 화재의 위험을 막으려면 유지관리 절차 단원의 “퓨즈 교체” 절에 설명된 것과 동일한 타입 및 정격의 제품으로 퓨즈를 교체하십시오.









警告: 火災予防のために、ヒューズ交換ではメンテナンス項目の「ヒューズの交換」に記載されているタイプおよび定格のヒューズをご使用ください。

Electrical and handling symbols



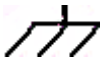
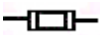

Electrical symbols

The following electrical symbols and their associated statements can appear in instrument manuals and on an instrument's front or rear panels.

	Electrical power on
	Electrical power off
	Standby
	Direct current
	Alternating current
	Protective conductor terminal
	Frame, or chassis, terminal
	Fuse

Handling symbols

The following handling symbols and their associated statements can appear on labels affixed to the packaging in which instruments, devices, and component parts are shipped.

	Keep upright!
	Keep dry!
	Fragile!
	Use no hooks!

B Installing the GC Column

The Agilent GC uses a capillary column, the inlet of which connects to the front or back GC inlet port. The outlet connects to the heated transfer line, which exits the oven at the bottom left-hand side.

See also: The Agilent GC user documentation.

GC oven internal schematic:

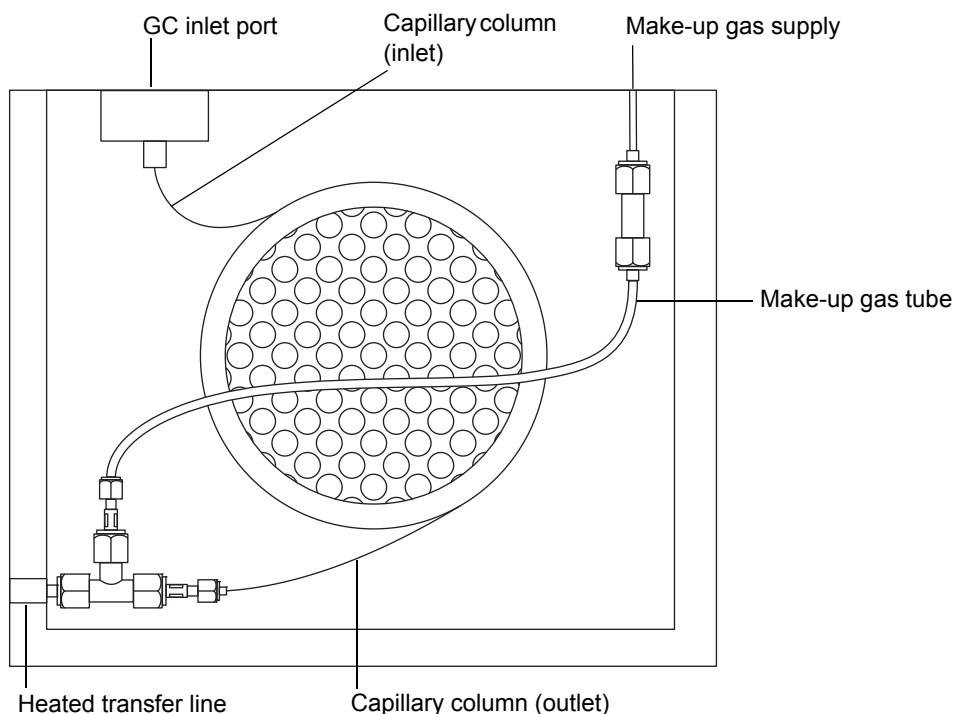

A make-up gas is supplied coaxially to the capillary column via a T-piece connected to the heated transfer line. An auxiliary EPC unit installed on the Agilent GC supplies and controls the make-up gas. To maintain constant make-up gas flow as the oven temperature changes, the make-up gas tube is configured as an auxiliary GC column that operates in constant-flow mode. The length of the make-up gas tube within the oven is critical, and only a Waters engineer should install it.

Required materials

- Ceramic wafer
- 1/4-inch wrench
- 4-mm wrench
- Agilent GC user documentation
- Eyeglass



Warning: To avoid eye injury, wear safety glasses when handling the capillary column, the ends of which are sharp.

To install the APGC column:

1. Referring to the Agilent GC user documentation, fit the capillary column to the GC oven frame.
2. Use the ceramic wafer to cut approximately 30 mm from the inlet end of the capillary column.

Rationale: Doing so removes any contaminated portion of the capillary column.

3. Connect the capillary column to the inlet at either the front or back inlet port of the Agilent GC, in accordance with the Agilent GC user documentation.
4. Feed the capillary column through the transfer line until approximately 30 mm of column is protruding.
5. Use the ceramic wafer to cut off the end of the capillary column.

Rationale: Doing so removes any contaminated portion of the capillary column.

6. Inspect the column end using an eyeglass.

Requirement: Ensure that the cut end is perpendicular to the column, even, and has no chips or rough edges, for a rough, ragged, or skewed end can reduce performance. Otherwise, repeat [step 5](#).

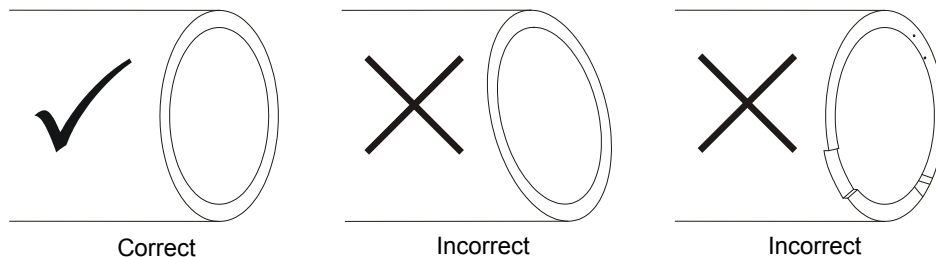

7. Retract the capillary column so that no more than 1 mm of the column tip extends from the source end of the heated transfer line (see [page 22](#)).
8. At the oven end of the heated transfer line, use the 4-mm wrench to grip the flat indents on the line while carefully tightening the end nut with the 1/4-inch wrench so that the column is held firmly but gently.

Fitting the capillary column to the heated transfer line:

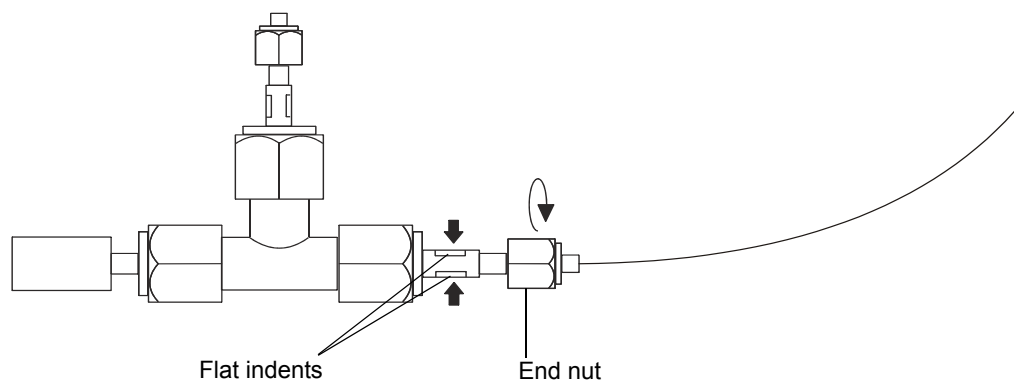

B Installing the GC Column

C Preparing Sample Vials

If you need to use reference or modifier samples, you must prepare vials for use with the APGC.

Contents:

Topic	Page
Preparing vials	80

Preparing vials

For both reference and modifier samples, you must use only closed vials when placing samples in the heated vial carrier.

Preparing closed vials

Required materials

- Chemical-resistant, powder-free gloves
- Ceramic wafer
- 1.5-mL crimp-top autosampler vials
- Septum caps
- Deactivated fused silica capillary (0.32-mm, 0.25 internal diameter, or both)
- Vial crimper
- Syringe

To prepare closed vials:

1. Place approximately 100 μL of sample in a crimp-top autosampler vial.
2. Use the vial crimper to secure a septum cap on the vial.



Warning: To avoid puncture and laceration injuries, take care when handling the capillary, which is fragile and easily broken.

3. Use the ceramic wafer to cut a 1-cm length of deactivated fused silica capillary.
4. Use the syringe to puncture the septum cap.
5. Insert the 1-cm length of deactivated fused silica capillary through the hole in the septum cap, leaving a 0.5-cm length protruding from the vial.

Preparing open vials

Required materials

- Chemical-resistant, powder-free gloves
- 1.5-mL crimp-top autosampler vials

To prepare open vials:

Place approximately 0.5 mL of modifier sample in a crimp-top autosampler vial.

C Preparing Sample Vials